

# Insertable filter with fan



The range of insertable filters available from Abraziv is especially suited for continuous removal of dust in industrial processes, or as an automatic cleaning-air filter for silos or containers under positive pressure.

The range includes a series of standardised filters with cloth surfaces from 2 m<sup>2</sup> up to 45 m<sup>2</sup>, whereby the air processing volume varies from 500 to 9,500 m<sup>3</sup> per hour.

Each filter can be separately hung in diverse transport systems and silos, or fitted as an integrated part of the process apparatus.

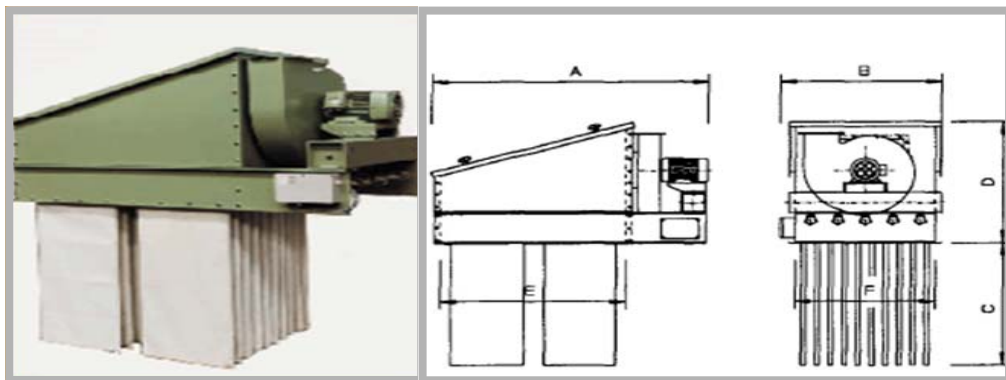

Type	Fan	KW	M <sup>2</sup>	No. of elements	A	B	Length of elements C	D	E	F	Weight (kg)
C-AAGF103	R07	0,37	2,8	4	1080	520	700	775	600	380	120
	R12	0,75			1080						
C-AAF104	R07	0,37	4,0	4	1080	520	1000	775	600	380	125
	R12	0,75			1080						
C-BAF104	R12	0,75	4,2	6	1180	700	700	960	600	560	155
C-AAF105	R12	0,75	5,0	4	1080	520	1250	775	600	380	130
C-AAF106	R12	0,75	6,0	4	1080	520	1500	775	600	380	135
C-BAF106	R12	0,75	6,0	6	1180	700	1000	960	600	560	165
	R15	1,1			1180						
C-CAF107	R12	0,75	7,0	10	1180	1060	700	960	600	920	235
	R15	1,1			1180						
C-CAF108	R12	0,75	7,5	6	1180	700	1250	960	600	560	170
	R15	1,1			1180						
C-BAF204	R12	0,75	8,4	12	1780	700	700	960	1200	560	245
	R15	1,1			1780						
C-BAF109	R12	0,75	9,0	6	1180	700	1500	960	600	560	180
	R15	1,1			1180						
	R18	3,0			1200						

Type	Fan	KW	M <sup>2</sup>	No. of elements	A	B	Length of elements C	D	E	F	Weight (kg)
C-CAF110	R15	1,1	10,0	10	1180	1060	1000	960	600	920	260
	R18	3,0			1200						270
C-BAF206	R15	1,1	12	12	1780	700	1000	960	1200	560	270
	R18	3,0			1800						280
C-CAF112	R15	1,1	12,5	10	1180	1060	1250	960	600	920	270
	R18	3,0			1200						280
C-BAF304	R15	1,1	12,6	18	2380	700	700	960	1800	560	345
	R18	3,0			2400						355
C-CAF207	R15	1,1	14,0	20	1780	1060	700	960	1200	920	390
	R18	3,0			1800						390
	R20	3,0			1800						395
C-CAF115	R15	1,1	15,0	10	1200	1060	1500	960	600	920	290
	R18	3,0			1200						290
	R20	3,0			1200						295
C-BAF208	R15	1,1	15,0	12	1780	700	1250	960	1200	560	290
	R18	3,0			1800						300
	R20	3,0			1800						305
C-BAF404	R15	1,1	16,8	24	2980	700	700	960	2400	560	435
	R18	3,0			3000						445
	R20	3,0			3000						450
C-BAF209	R18	3,0	18,0	12	1800	700	1500	960	1200	560	315
	R20	3,0			1800						320
C-BAF306	R18	3,0	18,0	18	2400	700	1000	960	1800	560	370
	R20	3,0			2400						375
C-CAF210	R18	3,0	20,0	20	1800	1060	1000	960	1200	920	425
	R20	3,0			1800						430
	R25	4,0			1800						445
C-CAF307	R18	3,0	21,0	30	2400	1060	700	960	1800	920	520
	R20	3,0			2400						525
	R25	4,0			2420						540
C-BAF308	R18	3,0	22,5	18	2400	700	1250	960	1800	560	400
	R20	3,0			2400						405
	R25	4,0			2420						420
C-BAF406	R18	3,0	24,0	24	3000	700	1000	960	2400	560	460
	R20	3,0			3000						465
	R25	4,0			3020						480

Type	Fan	KW	M <sup>2</sup>	No. of elements	A	B	Length of elements C	D	E	F	Weight (kg)
C-CAF212	R18	3,0	25,0	20	1800	1060	1250	960	1200	920	445
	R20	3,0			1800						450
	R25	4,0			1820						465
C-BAF309	R20	3,0	27,0	18	2400	700	1500	960	1800	560	425
	R25	4,0			2420						440
	R31	5,5			2550						465
C-CAF407	R20	3,0	28,0	40	3000	1060	700	960	2400	920	650
	R25	4,0			3020						665
	R31	5,5			3150						680
C-BAF408	R25	4,0	30,0	24	3020	700	1250	960	2400	560	505
	R31	5,5			3150						530
	R33	5,5			3150						545
C-CAF310	R25	4,0	30,0	30	2420	1060	1000	960	1800	920	570
	R31	5,5			2550						585
	R33	5,5			2550						610
C-CAF215	R25	4,0	30,0	20	1820	1060	1500	960	1200	920	485
	R31	5,5			1950						500
	R33	5,5			1950						525
C-BAF409	R25	4,0	36,0	24	3020	700	1500	960	2400	560	530
	R31	5,5			3150						555
	R33	5,5			3150						570
C-CAF312	R25	4,0	37,5	30	2420	1060	1250	960	1800	920	600
	R31	5,5			2550						615
	R33	5,5			2550						640
C-CAF410	R25	4,0	40,0	40	3020	1060	1000	960	2400	920	720
	R31	5,5			3150						735
	R33	5,5			3150						760
C-CAF315	R31	5,5	45,0	30	2550	1060	1500	960	1800	920	650
	R33	5,5			2550						675
	R35	7,5			2570						685
C-CAF412	R31	5,5	50,0	40	3150	1060	1250	960	2400	920	760
	R33	5,5			3150						775
	R35	7,5			3170						800
C-CAF415	R31	5,5	60,0	40	3150	1060	1500	960	2400	920	800
	R33	5,5			3150						815
	R35	7,5			3170						840