

HC-2500 type Overhead Conveyor Shot-blasting Machine



Application

The HC-2500 type shot blasting machine has been developed for surface cleaning of castings, forged parts, and smaller welded structures.

Description

The machine is equipped with four pieces of ABR-D400 direct driven impeller wheel type turbines.

They are arranged to blast in different parallel planes to assure a proper blast-cleaning effect on the entire surface of the work-pieces.

The turbines are of gravity abrasive feeding ones, having mechanic accelerator, control cage and 8 blades, thus assuring an accurate abrasive jet direction adjustment opportunity. The work-pieces to be cleaned are hanged onto a hand moved (optionally equipped with an electric motor driven winch) hanger device which will be brought into the middle point of the blasting chamber. During cleaning with closed inlet door the hanger device will stationary rotate in front of the turbines.

We supply two pieces of hangers fitted on the Y-shaped conveyor path to assure, that work pieces can be replaced on one during the blasting time of the other one.

The chamber internal surfaces in access of the active abrasive jet are covered with highly abrasion-resistant manganese steel plate, while other surfaces are protected with thick wear resistant rubber cover.

Blasting will only be possible, whenever the door is closed; this door assures proper protection against abrasive particles flying out.

The continuous and closed flow loop of abrasive is assured by a collecting hopper with screw, bucket elevator, windscreen, dosing unit and turbines.

For optimum surface cleanness the quantity and jet direction of the blasted abrasive can be accurately adjusted.

The ready parts hanger can be removed from the cabinet by hand after opening the door, and it can be simply replaced with the next charge.

To exhaust and filtrate the created dust during blast-cleaning we supply an APSZ type cartridge filter c/w fan and suitable ductwork.

A central control board will be supplied for controlling all functions of the machine.

Normal operation shall be carried out in automatic set position, however there is hand operation option also provided for service functions.

Blast pattern

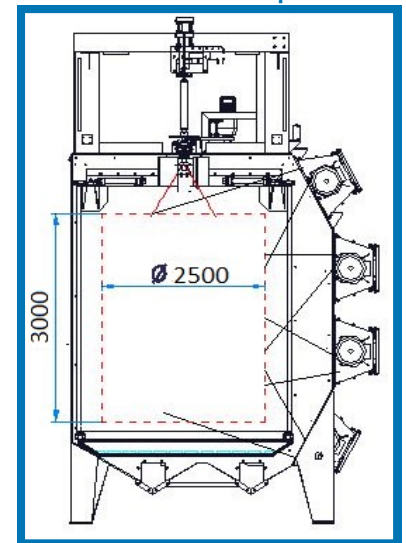

HC-2500

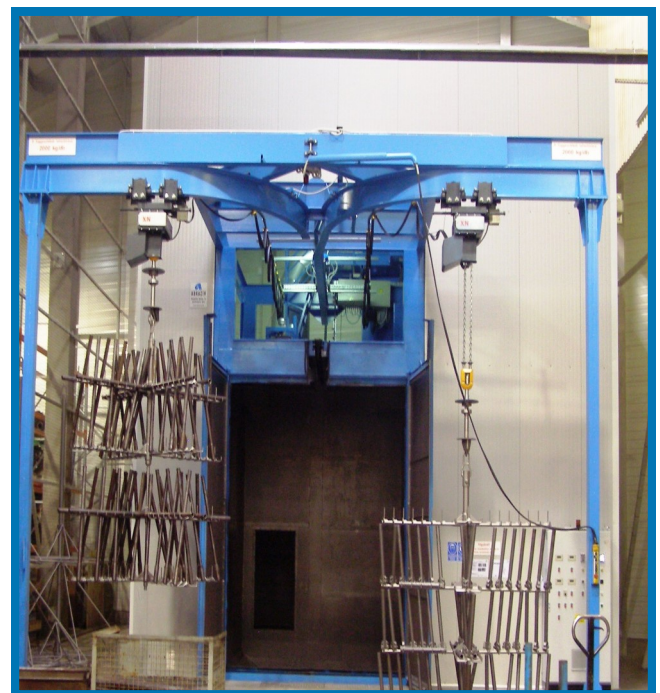

Measure print /HC-2500/

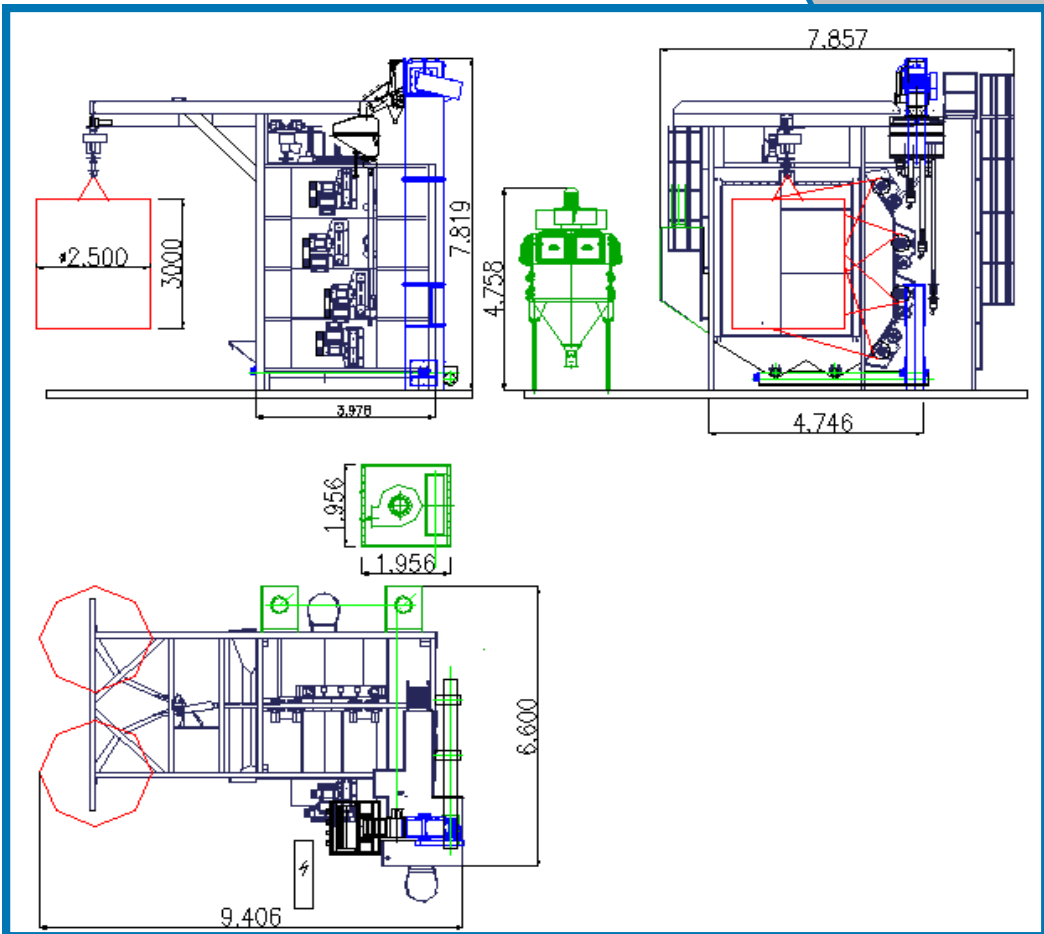

Technical data

Work piece-hanger theoretical max. measures:			
	Height	mm	3500
	Diameter	mm	2500
Turbines:	Quantity	pcs	4
	Type		ABR-D400
	Wheel diameter	mm	400
	Wheel speed	RPM	2940
	Abrasive capacity	kg/min/ turbine	130
	Turbine motor power	kW	7,5/turbine
Conveyor path:	Load capacity	kg/hanger	2000
Supply req.:	Electrical	Machine	kW 60
		Aspiration	kW 7,5
	Compressed air	Pressure	bar 6
		Air volume	m3/h 10
Abrasive charge:		kg	2400
Recommended abrasive particle size:		mm	0,4-1,2
Aspiration fan capacity		m3/h	12000
Electric data	Voltage	V	3 x 400
	Control voltage	V	220
	Cycles	Hz	50