

HC-1000 type Overhead Conveyor Shot-blasting Chamber Machine



Application

The HC-1000 type shot blasting machine has been developed for surface cleaning of castings, forged parts, and smaller welded structures.

Description

The machine is equipped with two pieces of ABR-380 impeller wheel type turbines.

They are arranged to blast in different parallel planes to assure a proper blast-cleaning effect on the entire surface of the work-pieces.

The turbines are of gravity abrasive feeding ones, having mechanic accelerator, control cage and 6 blades placed between two discs, thus assuring an accurate abrasive jet direction adjustment opportunity.

The work-pieces to be cleaned are hanged onto a hand moved hanger device which will be brought into the middle point of the blasting chamber. During cleaning with closed inlet door the hanger device will stationary rotate in front of the turbines.

We supply two pieces of hangers fitted on the Y-shaped conveyor path to assure, that work pieces can be replaced on one during the blasting time of the other one.

The chamber internal surfaces in access of the active abrasive jet are covered with highly abrasion-resistant manganese steel plate, while other surfaces are protected with thick wear resistant rubber cover.

Blasting will only be possible, whenever the door is closed; this door assures proper protection against abrasive particles flying out.

The continuous and closed flow loop of abrasive is assured by a collecting hopper with screw, bucket elevator, windscreen, dosing unit and turbines.

For optimum surface cleanness the quantity and jet direction of the blasted abrasive can be accurately adjusted.

The ready parts hanger can be removed from the cabinet by hand after opening the door, and it can be simply replaced with the next charge.

To exhaust and filtrate the created dust during blast-cleaning we supply a bag type filter c/w fan and suitable ductwork.

A central control board will be supplied for controlling all functions of the machine.

Normal operation shall be carried out in automatic set position, however there is hand operation option also provided for service functions.

Blasting pattern

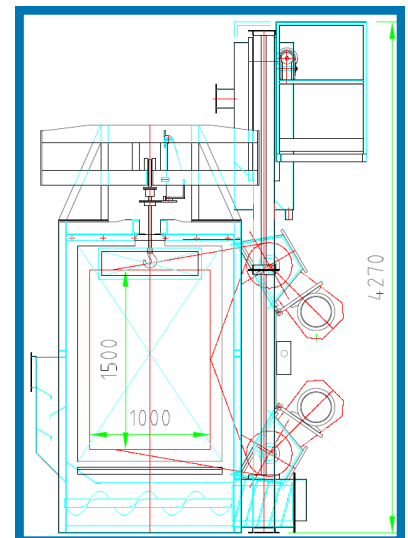

HC-1000



Measure print /HC-1000/

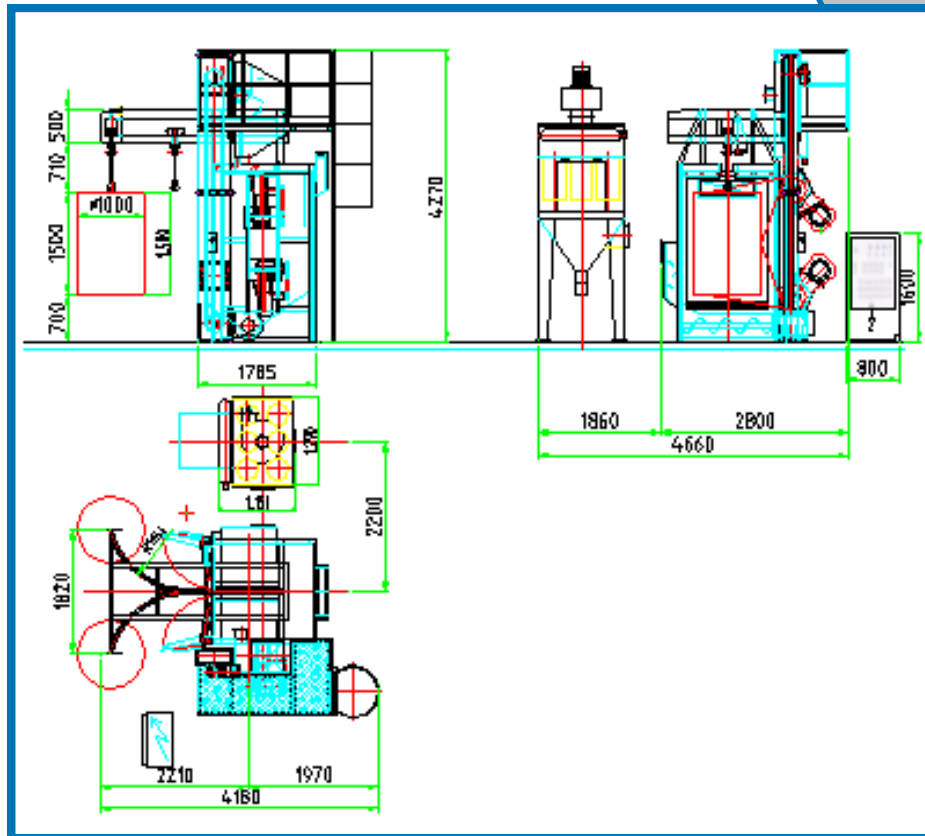

Technical data

Work piece-hanger theoretical max. measures:				
	Height		mm	1500
	Diameter		mm	1000
Turbines:	Quantity		pc	2
	Type		ABR-380	
	Wheel diameter		mm	380
	Wheel speed		RPM	2600
	Abrasive capacity		kg/min/	130
	Turbine motor power		kW	7,5 /each
Conveyor path:	Load capacity		kg/hanger	400
Supply requirements:	Electrical	Machine	kW	22
		Aspiration	kW	4
	Compressed air	Pressure	bar	6
		Air volume	m ³ /h	7
Abrasive charge:			kg	500
Recommended abrasive particle size:			mm	0,4-1,6
Aspirator fan capacity:			m ³ /h	4000
Electric data:	Voltage		V	3 x 400
	Control voltage		V	24
	Cycles		HZ	50