

CM-1000 type Continuous Over Head Conveyor Shot-blasting machine



Application

The CM-1000 type shot blasting machine is designed for blast cleaning castings, forged work-pieces and smaller dimension welded structures.

Description

The machine is mounted with two pieces of ABR-380 blasting turbines. The turbines are positioned on the machine housing in transitioned parallel blasting planes to ensure perfect cleaning effect on the whole surface of the hanging bunches.

The turbines are gravity fed constructions with mechanic accelerator impeller wheel and control cage. The wheels have 6 blades mounted between two parallel plates. These features provide precise blast pattern adjustment. The work-pieces to be cleaned are hung on hangers. These hangers are placed on hand operated conveyor trolleys (optionally electromechanically operated). When the hanger enters the machine housing an automatic mechanism pulls it to blasting positions. Blast cleaning happens behind closed pneumatically operated doors. During cleaning process the hangers continuously rotating in front of the turbines.

When blasting is finished the work-pieces leave on the exit side of the chamber and a new bunch arrives to blasting position.

In the active zones the inner surface of the machine housing is covered with highly wear resistant manganese steel.

Blasting will only be possible, whenever the door is closed; this door assures proper protection against abrasive particles flying out.

The continuous and closed flow loop of abrasive is assured by a collecting hopper with screw, bucket elevator, windscreen, dosing unit and turbines.

For optimum surface cleanness the quantity and jet direction of the blasted abrasive can be accurately adjusted.

The conveyor path dimensions and shapes can be adjusted to the client's demands.

To exhaust and filtrate the created dust during blast-cleaning we supply an APSZ type cartridge filter c/w fan and suitable ductwork.

A central control board will be supplied for controlling all functions of the machine.

Normal operation shall be carried out in automatic set position, however there is hand operation option also provided for service functions.

Blast pattern

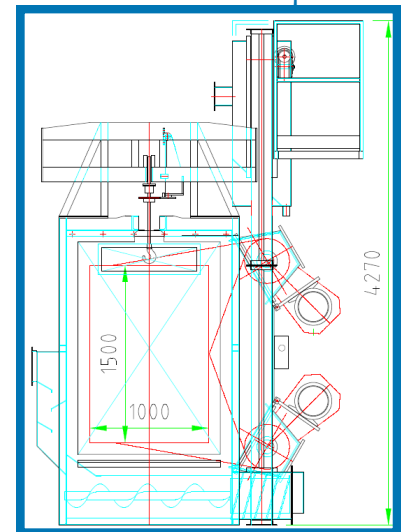

CM-1000



Measure print /CM -1000/

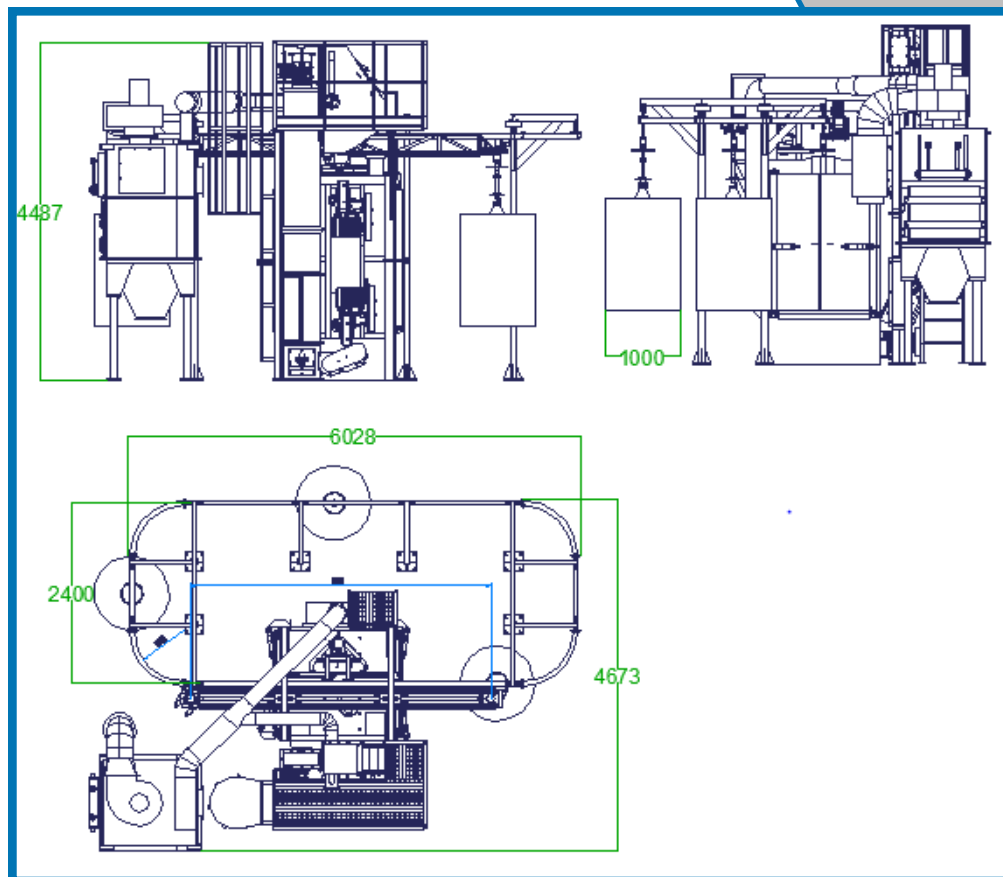

Technical data

Work piece-hanger theoretical max. measures:			
	Height	mm	1500
	Diameter	mm	1000
Turbines:	Quantity	pcs	2
	Type		ABR-380
	Wheel diameter	mm	380
	Wheel speed	f/p	2600
	Abrasive capacity	kg/min/ turbine	130
	Turbine motor power	kW	7,5 /turbine
Conveyor path	Load capacity	kg/hanger	500
Supply req.:	Electrical	Machine	kW
		Aspiration	kW
	Compressed air	Pressure	bar
		Air capacity	m3/h
Abrasive charge:		kg	500
Recommended abrasive size:		mm	0,2-1,6
Aspiration fan capacity:		m3/h	4000
Electrical data:	Voltage	V	3 x 400
	Control voltage	V	110
	Cycles	Hz	50