

ST-1000 type Continuous Overhead Conveyor Shot-blasting Machine



Application

The ST-1000 type shot-blasting machine is mainly suitable for cleaning the surfaces of long welded structures and beam alike work-pieces.

Technical description

The machine has 8 pieces of ABR-D400 turbines. These turbines are mounted on the machine housing in angular blasting planes to ensure perfect cleaning effect on the whole surface of the work-piece.

The turbines are of gravity abrasive feeding ones, having mechanic accelerator, control cage and 8 blades to ensure an accurate abrasive jet direction adjustment opportunity.

The work-pieces to be blast cleaned enter the machine housing by the means of electro mechanic overhead conveyor via multiple layer rubber curtains.

The conveyor moves continuously with the hung work-piece in front of the blasting turbines.

The chamber internal surfaces in access of the active abrasive jet are covered with highly abrasion-resistant manganese steel plate, while other surfaces are protected with thick wear resistant rubber cover.

Both at the inlet and outlet side of the machine housing a channel ensures that the abrasive will not burst out.

The continuous and closed flow loop of abrasive is assured by a collecting hopper with screw, bucket elevator, air classifier abrasive cleaning unit, dosing unit and turbines.

For optimal cleaning effect the abrasive amount and the blasting direction can be adjusted as well.

The conveyor path can be designed according to the demands of our client.

To exhaust and filtrate the created dust during blast-cleaning we supply an APSZ type cartridge filter c/w fan and suitable ductwork.

The air leaving filtration system has less dust content than 2 mg/m^3 .

The shot-blasting machine can operate as an individual equipment or it can be a part of a complete surface treatment line.

The operation of the machine is optionally continuous or tactual.

The noise level of the machine is over 85dB (A) but with sound isolation it can be reduced.

A central control board will be supplied for controlling all functions of the machine.

Normal operation shall be carried out in automatic set position, however there is hand operation option also provided for service functions.

Blast pattern

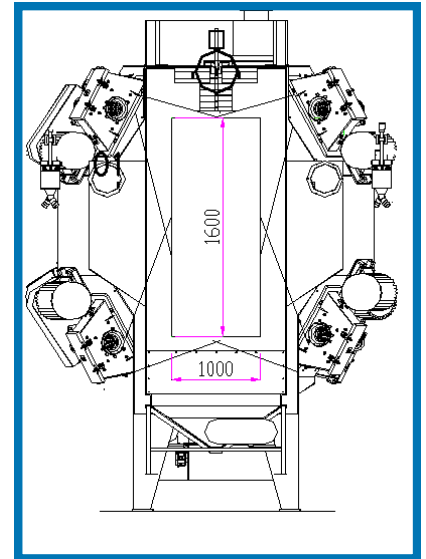

ST-1000



Measure print /ST-1000/

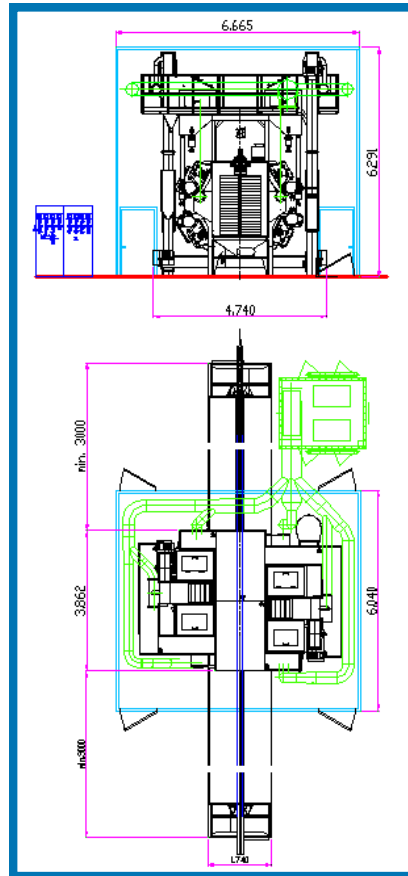

Technical details (adjustable to customer demands)

The work-piece theoretical outer dimensions:				
	Height	mm	1600	
	Width	mm	1000	
Turbines:	Quantity	pcs	8	
	Type	ABR-D400		
	Wheel diameter	mm	400	
	Wheel speed	RPM	2900	
	Abrasive capacity	kg/min/ turbine	130	
	Turbine motor power	kW	7,5 /turbine	
Conveyor:	Load capacity	kg/m	2000	
Supply req:	Electrical	Machine	kW	75
		Aspiration	kW	15
	Compressed air	Pressure	bar	6
		Capacity	m ³ /h	15
Abrasive charge:		kg	3000	
Recommended abrasive size:		mm	0,2-1,6	
Aspiration fan capacity:		m ³ /h	16000	
Electrical data:	Voltage	V	3 x 400	
	Control voltage	V	110	
	Cycles	Hz	50	