

Filtr punktowy do zamocowania na przenośniku

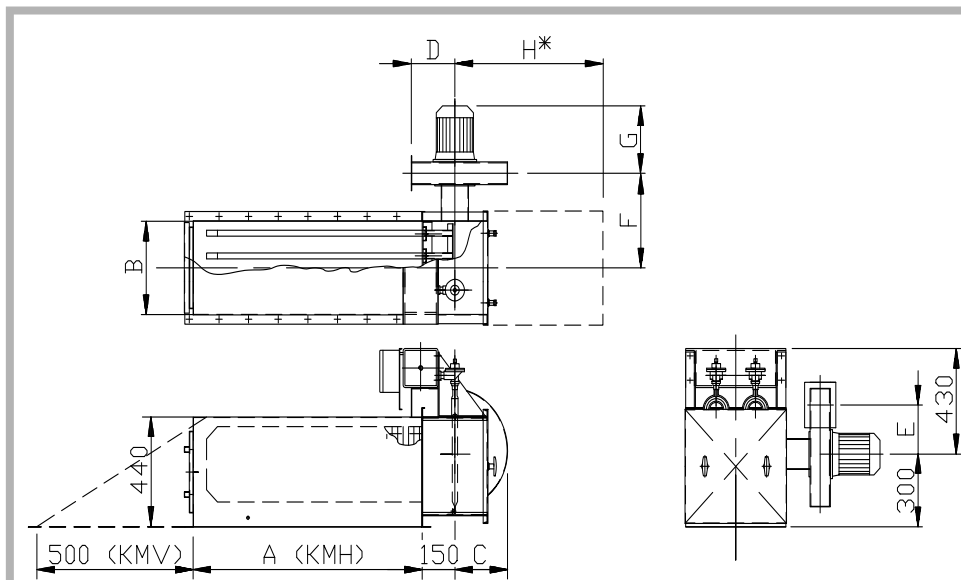
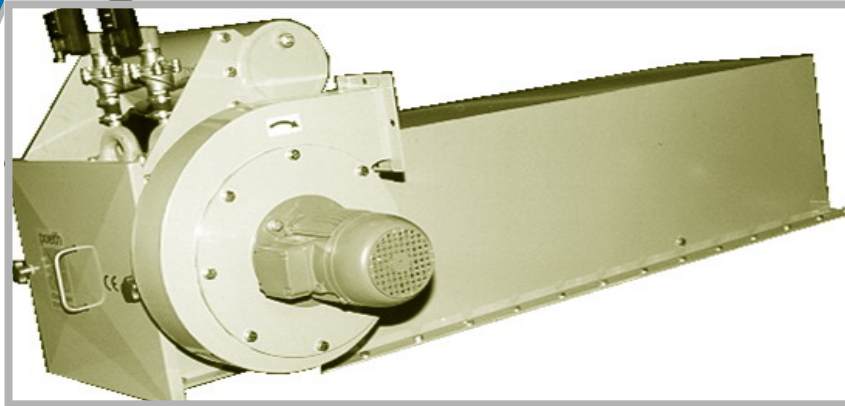

Typ	m ²	Liczba rękawów:	Długość rękawa	A	B	C	D	E	F	G	H	Ciężar [kg]
KMH(V)2/10R07	1,4	2	1000	1050	200	199	200	174,5	285	245	900	148
KMH(V)2/15R07	2,1	2	1500	1550	200	199	200	174,5	285	245	1400	158
KMH(V)2/20R07	2,8	2	2000	2050	200	199	200	174,5	285	245	1900	168
R12						242		201	388	284		168
KMH(V)4/10R07	2,8	4	1000	1050	380	199	200	174,5	285	245	900	162
R12						242		201	388	284		162
KMH(V)4/15R07	4,2	4	1500	1550	380	199	200	174,5	285	245	1400	178
R12						242		201	388	284		178
KMH(V)4/20R07	5,6	4	2000	2050	380	199	200	174,5	285	245	1900	194
R12						242		201	388	284		194
KMH(V)6/10R07	4,2	6	1000	1050	560	199	200	174,5	285	245	900	176
R12						242		201	388	284		176
KMH(V)6/15R12	6,3	6	1500	1550	560	242	200	201	388	284	1400	208
R15						298	300	236	492	298		218
KMH(V)6/20R12	8,4	6	2000	2050	560	242	200	201	388	284	1900	220
R15						298	300	236	492	298		230

Sprężone powietrze (5 bar)

Typ	Interval [sec]	Czas trwania impulsu [msec]	Ilość powietrza: [Nm ³ /h]	Króciec Ø
KMH(V)2/10	120	60	0,8	1/2"
KMH(V)2/15	120	90	0,9	1/2"
KMH(V)2/20	120	120	1,2	1/2"
KMH(V)4/10	60	60	1,6	1/2"
KMH(V)4/15	60	90	1,8	1/2"
KMH(V)4/20	60	120	2,0	1/2"
KMH(V)6/10	40	120	2,4	1/2"
KMH(V)6/15	40	150	2,6	1/2"
KMH(V)6/20	40	200	2,8	1/2"

Wentylatory

Typ	Transport przy ciśnieniu 1000 Pa [m ³ /h]	Silnik [kW]	Poziom hałasu bez tłumika [dB(A)]	Poziom hałasu z tłumikiem [dB(A)]
R07	390	0,37	86	70
R12	880	0,75	88	74
R15	1500	1,1	88	75

