

Oscillating grid slide



Application

This slide is specially designed for dosing of products with difficult flow-properties out of silo-bins, hoppers etc.

Depending on the type of execution also fragile products can be discharged with great care and accuracy.

Even aeration of silos through these slides is possible.

Operation

The intermediate slide-platform is connected to the motor drive-unit.

The position “closed” is guarded by a proximity switch. Starting the motor, the slide is opened completely and then closed again.

Opening positions can be fixed with the help of one or more proximity switches.

The through-put capacity can be regulated by modification of the interval period between openings.

Benefits

- Highly reliable unit.
- Large throughput.
- Large moving slide part for optimum discharge-properties.



Construction

- Strong welded housing.
- Motor drive-unit.

Optional extras

- Aeration provisions.



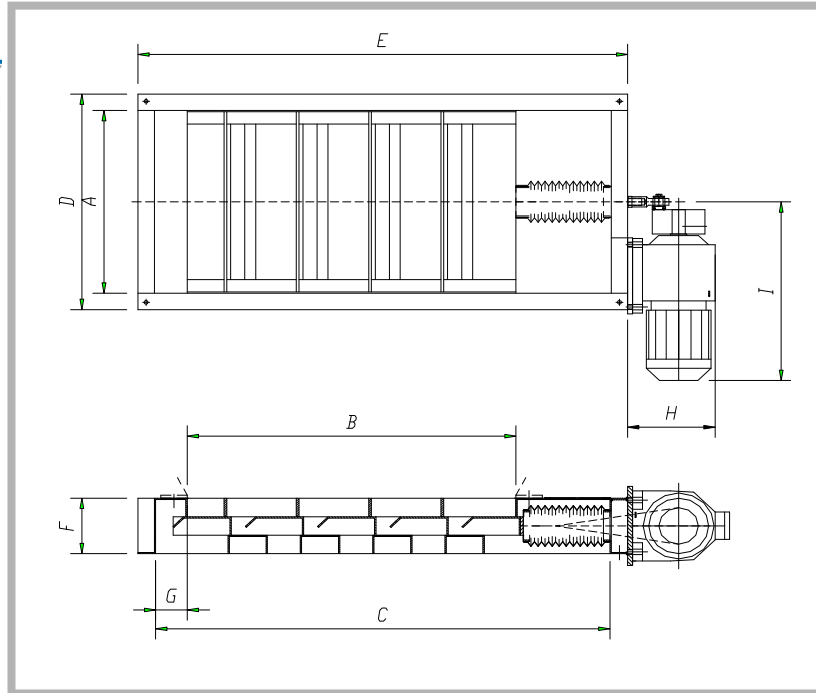

Type	A	B	C	D	E	F	G	H	I	Drive power	Number of slides
RSM40/56	400	560	942	508	1050	182	96	266	586.5	1,1 kW	3
RSM60/78	600	780	1162	708	1270	182	96	266	586.5	1,1 kW	4
RSM60/100	600	1000	1382	708	1490	182	96	266	586.5	1,1 kW	5
RSM60/122	600	1220	1602	708	1720	182	96	266	586.5	1,1 kW	6
RSM80/122	800	1220	1602	908	1720	182	96	266	586.5	1,1 kW	6

