

# RB-600 roller-path type shot-blasting machine



## Application

The RB-600 shot-blasting machine is mainly suitable for the low investment cost de-rusting, de-scaling and cleaning of

- steel plates
- bar and sectional steel
- pipes, profiles and simple welded steel constructions.

## Description

The machine is equipped with two pieces of ABR 400 type blasting turbines. One of these turbines is situated above the roller-path top level and the other one is placed under it to ensure the possible best covering of the through-pass cross section. Blasting is done in a perpendicular angle to the direction of advancement.

The turbines are gravity fed with abrasive material, they have eight blasting blades and a pre-accelerator and they allow precise blasting direction adjustment.

The inner surfaces of the machine in the active zone are covered with highly wear-resistant manganese steel, other inner parts are protected by wear-resistant rubber sheet. This rubber cover has noise-reducing effect as well. Rollers in the machine house are also protected from the abrasive media either by profile rubber segments, or they are made of high manganese alloy steel pipe that ensures long life time.

The three-layer rubber curtains at the inlet and outlet sluice prevent the high velocity abrasive particles from shooting out.

The closed and continuous circulation of the shot-blasting media is ensured by a screw conveyor, bucket elevator, abrasive cleaning wind-sifter unit and a feeding unit.

The clean work-piece is de-dusted by a blow-off fan built on the exit section of the machine.

The dust-aspirating and separating system of the equipment consists of galvanized steel air-ducts, form-elements, aspiration fan and filter cartridge inserted dust-separator.

Dust emission after the filter is not more than  $3\text{mg}/\text{m}^3$ .

All functions of the machine can be controlled from the central control box. Besides the normal mode of operation (automatic mode) manual mode is also available for maintenance purposes.

## RB-600 blasting pattern

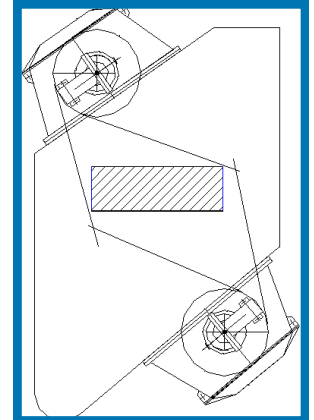

Due to the machine basic construction it is advisable to drive work-pieces having complicated shape twice through the tunnel.

## RB-600





## Measure print /RB-600/

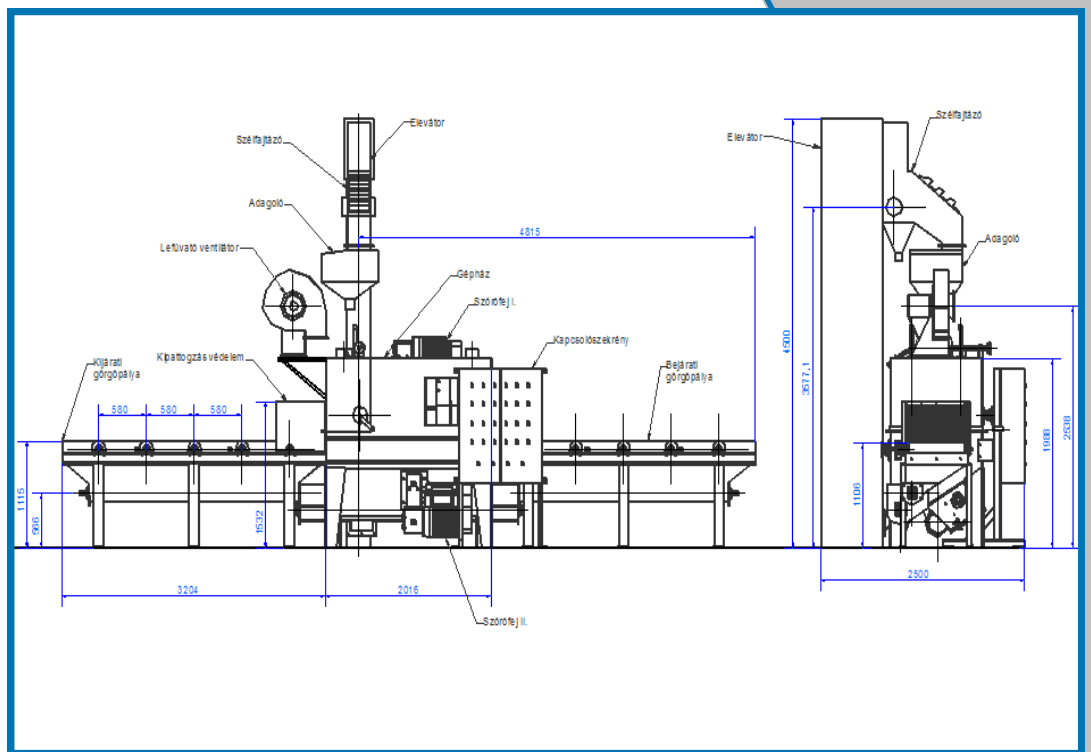

## Technical data

Through-pass width	mm	600
Min. work-piece length (shorter pieces can be cleaned by means of a so-called auxiliary frame)	mm	about 1200
Max. height of work-piece	mm	300
Turbines		
Number	piece	2
Type		ABR-400
Diameter	mm	400
Wheel speed	1/min	2600
Abrasive capacity / per turbine	kg/min	130
Rollerpath		
Loadability	kg/m	1000
Speed range	m/min	0-4
Energy demand		
Electrical		
Basic machine	kW	22
Dust aspiration	kW	5-5
Compressed air		
Pressure	bar	min.6
Quantity (filter)	l/min	2,2 ( 100)
Abrasive charge	kg	800
Proposed abrasive particle size	mm	0,4-1,2
Air to be aspirated	m <sup>3</sup> /h	4000
Electrical data		
Mains voltage	V	3 × 380
Control voltage	V	220
Frequency	Hz	50