

CM-2000 type Continuous Over Head Conveyor Shot-blasting machine



Application

The CM-2000 type shot blasting machine is designed for blast cleaning castings, forged work-pieces and smaller dimension welded structures.

Description

The machine is mounted with 4 pieces of ABR-D400 blasting turbines. The turbines are positioned on the machine housing in transitioned parallel blasting planes to ensure perfect cleaning effect on the whole surface of the hanging bunches.

The turbines are gravity fed constructions with mechanic accelerator impeller wheel and control cage. The wheels have 8 blades. These features provide precise blast pattern adjustment.

The work-pieces to be cleaned are hung on hangers. These hangers are placed on electromechanically operated conveyor trolleys. When the hanger enters the machine housing an automatic mechanism pulls it to blasting positions. Blast cleaning happens behind closed pneumatically operated doors. During cleaning process the hangers continuously rotating in front of the turbines.

When blasting is finished the work-pieces leave on the exit side of the chamber and a new bunch arrives to blasting position.

In the active zones the inner surface of the machine housing is covered with highly wear resistant manganese steel.

Blasting will only be possible, whenever the door is closed; this door assures proper protection against abrasive particles flying out.

The continuous and closed flow loop of abrasive is assured by a collecting hopper with screw, bucket elevator, windscreen, dosing unit and turbines.

For optimum surface cleanness the quantity and jet direction of the blasted abrasive can be accurately adjusted.

The conveyor path dimensions and shapes can be adjusted to the client's demands.

To exhaust and filtrate the created dust during blast-cleaning we supply an APSZ type cartridge filter c/w fan and suitable ductwork.

A central control board will be supplied for controlling all functions of the machine.

Normal operation shall be carried out in automatic set position, however there is hand operation option also provided for service functions.

Blast pattern

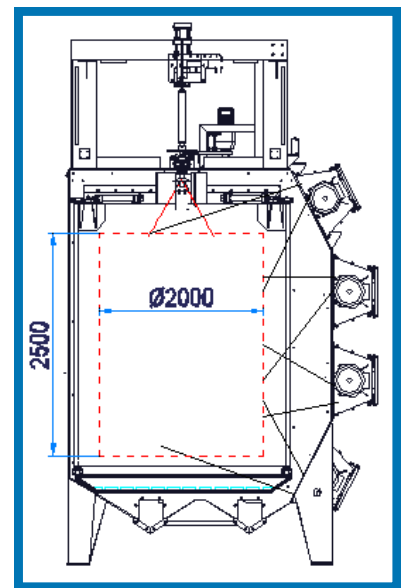

CM-2000



Measure print /CM -2000/

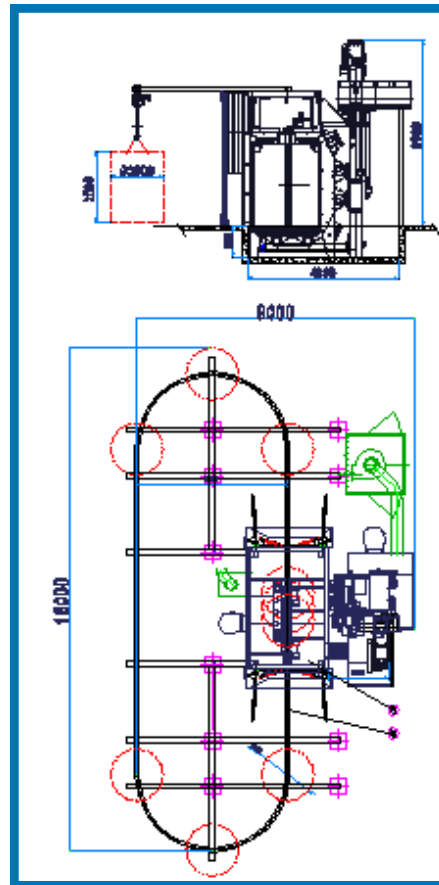

Technical data

Work piece-hanger theoretical max. measures:			
	Height	mm	2500
	Diameter	mm	2000
Turbines:	Quantity	db	4
	Type	ABR-400	
	Wheel diameter	mm	400
	Wheel speed	f/p	2900
	Abrasive capacity	kg/min/ turbine	130
	Turbine motor power	kW	7,5 /turbine
Conveyor path	Load capacity	kg/hanger	2000
Supply req.:	Electrical	Machine	kW 51
		Aspiration	kW 7,5
	Compressed air	Pressure	bar 6
		Air capacity	m ³ /h 10
Abrasive charge:		kg	2400
Recommended abrasive size:		mm	0,2-1,6
Aspiration fan capacity:		m ³ /h	12000
Electrical data:	Voltage	V	3 x 400
	Control voltage	V	110
	Cycles	Hz	50